



PT. BRILIAN SUKSES MANDIRI

INNOVATE YOUR ENGINEERING LIFE WITH US



Company Profile



Jl. Baung No.3A
Lenteng Agung Jagakarsa
South Jakarta 12610 - INDONESIA



bsm@brilian-sm.com
+62 21 7815850



www.brilian-sm.com

CONTENTS

Hot Tap summary
BSM range of service
Hot Tap Application and Capabilities
Step in Hot Tapping
Reference Work

Well Tango Kalimantan
Benuotaka Field Kalimantan
Pertamina Dumai
Indorama Plant
Prabumulih
Pertamina Gede Bage



HOTTAP SERVICES



HOTTAP PRODUCT



EXPERIENCE LIST

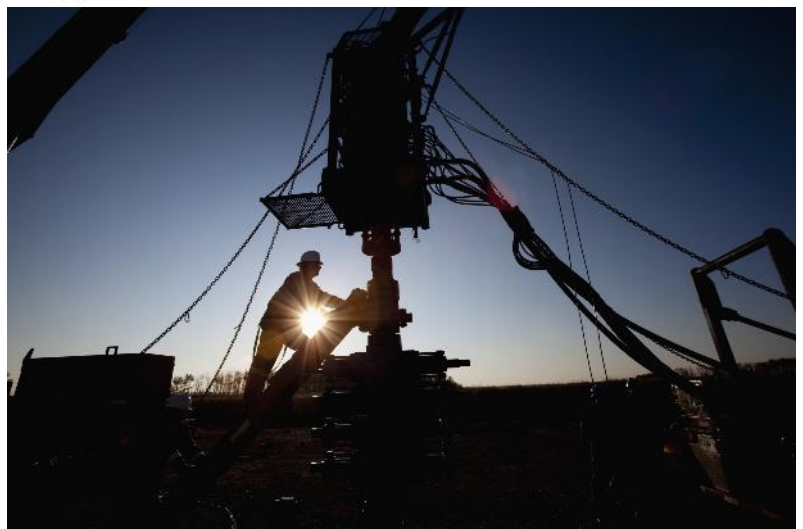

HOT TAP

Service / Application / Capabilities



HOT TAPPING SERVICES

In order to enhance the service for our customer in Hot Tap service, PT. Brilian Sukses Mandiri with Mechanical Service division are establishing a recognized as leader in the Hot Tapping and Line Stopping industry.

Whether you require a small-bore emergency application or a larger planned modification – PT. Brilian Sukses Mandiri Hot Tapping gets the job done and done right. PT. Brilian Sukses Mandiri has the expertise to evaluate and customize a solution that specically meets your application and plant needs.

A Hot Tap is denned as using a drilling machine to cut hole into an in -services, under-pressure piping system. This is done without service interruption or product leakage. Typical applications of Hot Tap normally include fitting designed to contain system pressure, a valve used to control the new connection and a drilling or Tapping Machine.

HOT TAPPING

STEPS IN HOT TAPPING

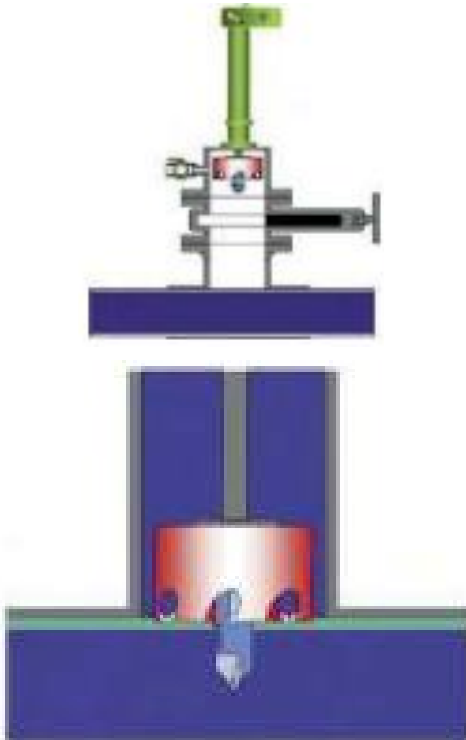

STEP 1 : For a hot tap, there are three key components necessary to safely drill into a pipe; the fitting, the valve, and the hot tap machine. The fitting is attached to the pipe, mostly by welding.

STEP 2 : The fitting/valve combination, is attached to the pipe, and is normally pressure tested. The pressure test is very important, so as to make sure that there are no structural problems with the fitting, and so that there are no leaks in the welds.

STEP 3 : The hot tap cutter is attached to a cutter holder, with the pilot bit, and is attached to the working end of the hot tap machine, so that it fits into the inside of the tapping adapter. The tapping adapter will contain the pressure of the pipe system, while the pipe is being cut, it houses the cutter, and cutter holder, and bolts to the valve.

STEP 4 : The Hot Tap is made in one continuous process, the machine is started, and the cut continues, until the cutter passes through the pipe wall, resulting in the removal of a section of pipe, known as the "coupon". Once the cutter has cut through the pipe, the hot tap machine is stopped, the cutter is retracted into the hot tap adapter, and the valve is closed.

STEP 5 : Pressure is bled off from the inside of the Tapping Adapter, so that the hot tap machine can be removed from the line. The machine is removed from the line, and the new service is established.

HOT TAPPING

CAPABILITIES AND APPLICATION

Capabilities :

PT. Brilian Sukses Mandiri Is equipped to handle your all of your Hot Tap needs. We carry large and most diverse inventory of Hot Tapping Equipment in Indonesia. We have a proven record of developing unique and custom Hot Tap solution for the most complicated scenarios.

- ◆ Hot Tap performed in size ranges from 1/2 inch through 18 Inches
- ◆ Hot Tap performed on system operating over 1000 PSI
- ◆ Hot Tap performed on system operating to 700 Degrees F.

Hot Taps performed on variety of piping and vessels materials including the following : Carbon Steel, Stainless Steel, Cast/Ductile Iron, Prestressed Concrete Cylinder Pipe, Reinforced Concrete Pipe, Transite or Asbestos Cement, Exotic Alloys, PVC, Polyethylene, and others.

Virtually every Hot Tapping job is deferent, and require Hot Tap Procedure before starting the job. Every procedure may need revision to Unique job specific problems or situations that may arise concerning the safety of personnel and facilities. Most Hot Tapping applies to piping and equipment fabricated from ferrite and austenitic steel. Other materials, such as aluminum, copper, plastic, and cast iron may be unsuitable for Hot Tapping or welding or may require Special Procedure.

Application :

- ◆ New Construction tie-ins without shutdown
- ◆ Re-Route pipeline construction
- ◆ Installation of by-pass systems
- ◆ Installation Block Valve
- ◆ Pressure and vacuum gauge installation
- ◆ Quality control sample points
- ◆ Thermowell Coupling installation
- ◆ Chemical injection point
- ◆ Corrosion coupon installation
- ◆ Orifice taps for flow meters
- ◆ Onshore service
- ◆ Pipe Inspection
- ◆ Temperature indicators
- ◆ Sparger installations

HOT TAPPING RANGE

We are able to perform Hot Taps into most mediums such as Hydrocarbons, Natural gas, Water, Waste water, Steam, Condensate, Compressed air and heavy oils, and can be effectively deployed in a variety of industries, including :

- ◆ Fossil, Hydro and nuclear power generation
- ◆ Offshore and Onshore oil and gas production facilities and pipelines
- ◆ Refineries and petrochemical plants
- ◆ Oil and Gas Transmission and distribution pipelines
- ◆ The steel industry, Pharmaceutical, Food processing, and Pulp paper plants
- ◆ Waste water Transmission and distribution Pipe line
- ◆ Air Conditioner line on high building

PT. BRILIAN SUKSES MANDIRI

Has a full range of Hot Tapping Equipment as follows :

TDW 101XL	Range Size : 1/2" - 6"	Driven by: Manual/Hydraulic
TM 305	Range Size : 1/2" - 3"	Driven by: Manual/Hydraulic
TM 760	Range Size : 3" - 16"	Driven by: Hydraulic
TRDN 10-04	Range Size : 8" - 18"	Driven by: Hydraulic

Available off the shelf for up to 1480 psig maximum operating pressure and temperatures as high as 700°F. Custom design and packet offered for higher system requirements.

Some of PT. Brilian Sukses Mandiri Hot Tap machines is design and fabricated by our shelf to perform Hot Taps from ½ inch to 18 inches. (*API 2201 Section 7*)

PT. Brilian Sukses Mandiri Hot Tapping Machine

Features :

Available in size ranges ½ inch through 18 inch diameter cut sizes and a boring bar stroke (reach) of over 66 inches.

LINE STOP STOPPLE PLUG

Line stopping is a means of temporarily inserting a plugging device to shut off the flow of an in-service piping system. Line stopping can be used to isolate sections of pipe for repair, maintenance, or reconfiguration such as adding valve. If used with a bypass, work can be performed without service interruptions.

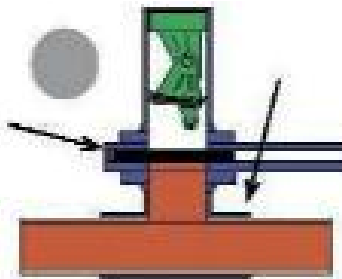

STEP 1 : AFTER A HOT TAP MAKES IT'S LIVE HOLE IN THE PIPE. A LINE STOPPING MACHINE IS BOLTED TO THE TAPPING VALVE.

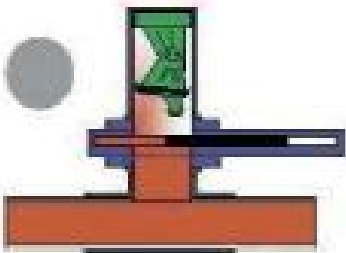

STEP 2 : THE TAPPING VALVE IS OPENED. PIPE CONTENTS ENTER THE LINE STOP MACHINE.

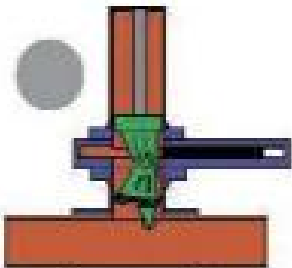

STEP 3 : THE LINE STOP MACHINE ACTUATOR INSERTS A HIGH - PRESSURE STEEL PLUGGING HEAD DOWN THROUGH THE OPEN VALVE AND INTO THE PIPE THROUGH THE HOLE...

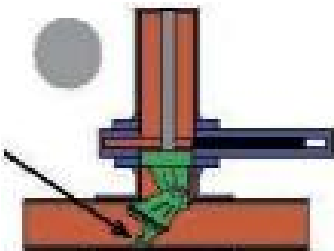

STEP 4 : ...WHERE A ROLLER CONTACTS THE PIPE INNER WALL, AND THE PLUGGING HEAD WALKS AND PIVOTS INTO THE SEALING POSITION.

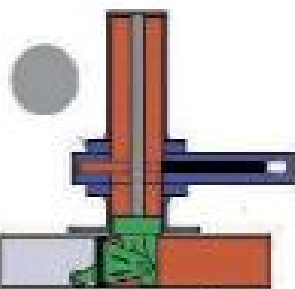

STEP 5 : THE PLUGGING HEAD'S FIBER - REINFORCED ELASTOMETRIC SEALING ELEMENT IS NOW TEMPORARILY PLUGGING THE PIPE. DOWNSTREAM OF THE PLUG, THE PIPE CAN BE DEPRESSURIZED, DRAINED AND MODIFIED OR REPAIRED. ONCE WORK ONE THE PIPE IS COMPLETED. THE DOWNSTREAM IS REPRESSURIZED AND THE PLUGGING HEAD REMOVED.

LINE STOP

STOPPLE PLUG

INSTALLING A COMPLETION PLUG

01.

After a Line Stop job is done, a Completion Plug setting machine is attached to the tapping valve, and a Completion Plug is lowered through the valve into the throat of our special completion flange.

02.

Next, high speed steel retainer segments are advanced from inside the flange, into a deep groove in the steel Completion Plug.

03.

With the plug's massive O-Ring sealing the flange bore, the tapping valve and machinery can be depressurized and removed.

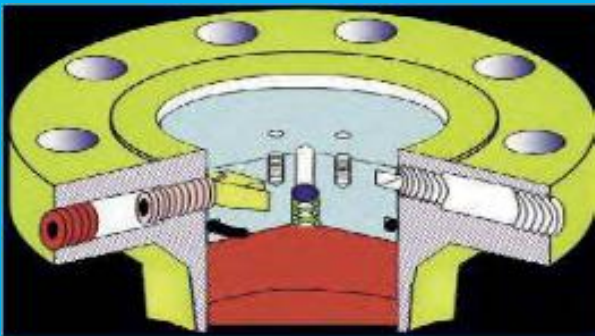

LINE STOPPING

PT. Brilian Sukses mandiri manufactures a complete High Pressure Pipe Plugging System for the temporary blockage of and pipe a valve is not our standards system is designed for 1000 psig differential across plugging head.

PT. Brilian Sukses Mandiri expert is the enhancement and refinement with placed around Indonesia to cover all sizes of pipes.

We will be there on time and get the job done.



HOTTAP FOR THERMOWELL & PRESSURE INSTALLATION

A Fitting is welded onto the pipe or vessel. A permanent valve is installed on to the fitting.

Completed BSM tool for Hot Tap is prepared. Installed Scaffolding if necessary.

A BSM tool for Hot Tap is installed on the valve

The Valve opened

A Leaking test for tool connection A Pilot Drill penetrates

The tap is made through the pipe wall. The valve is closed and the BSM tapping tool is removed.

The Hot Tap work is Complete

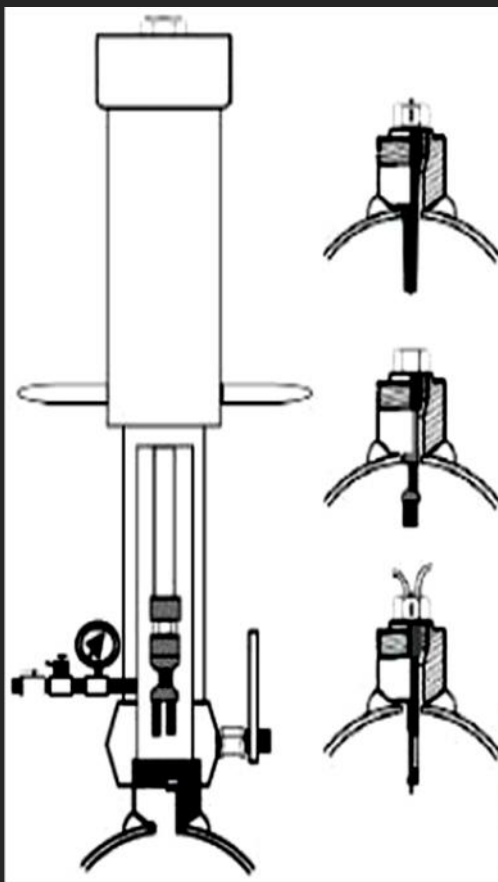
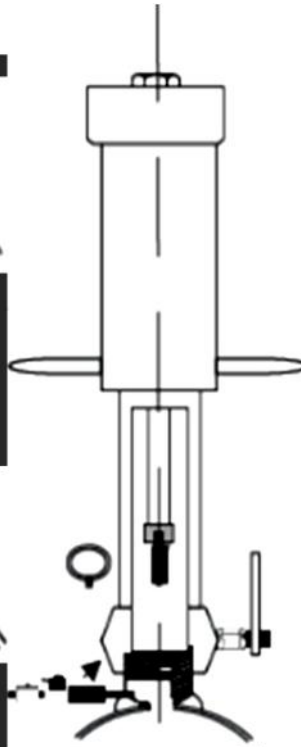

System Insertion and Removal Sensor Equipment Service

To Access the device (sensor) without process interruption or shutdown A service valve and BSM Tool for retrieve are attached to the fitting

Once pressure equalization between the line and the BSM tool has been achieved the sensor is insert to the



General Considerations

Is use of Hot Tap Appropriate

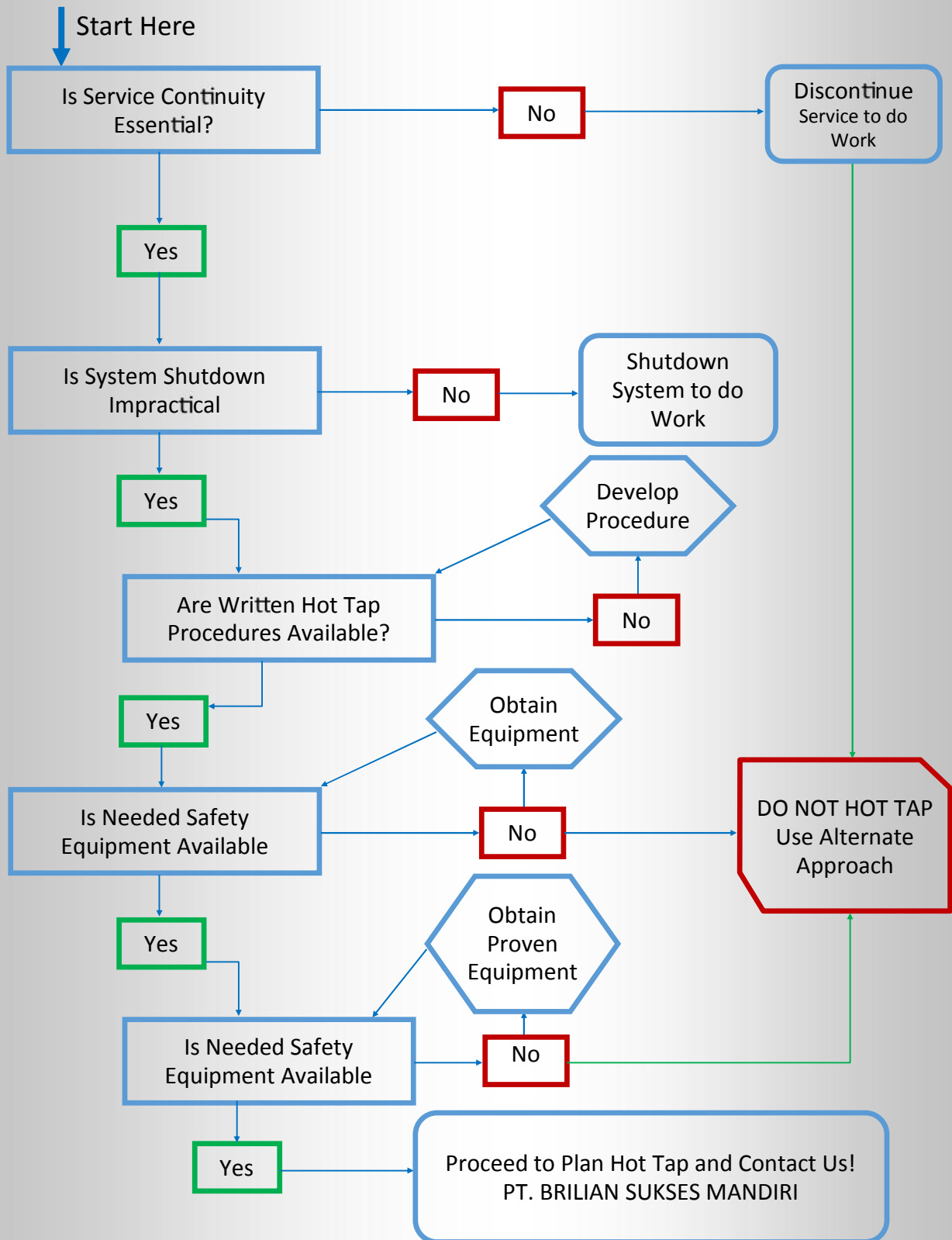



HORIZONTAL HOT TAPPING

14" 150#
PT. INDORAMA

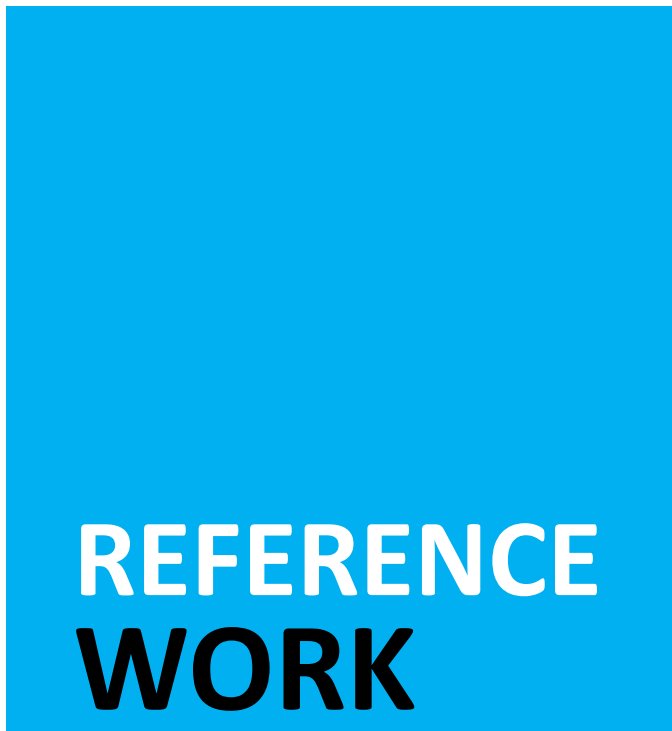

12" X 16"
CARBON STEEL

HOT WATERLINE
INDORAMA PLANT

PRESSURE
600 PSI



HOT TAP, RETRIEVAL LOCK O RING PLUG 12" 300#, TANJUNG JUMLAI CHEVRON KLO



HOT TAP 2" 300# BENUOTAKA, LAWE-LAWE, KALTIM



HOT TAP 4" 300# MINAS CHEVRON SMO



HOT TAP FOR SAMPLE POINT ON TANK



HOT TAP & STOPPLE 12" X 12" 600# PERTAMINA GEDEBAGE



HOT TAPS & LINE STOPS

Weld and Sleeve Fittings & accessories
Manufacturing

SPLIT LINE STOP TEE FITTINGS

Product Summary :

- ◆ Full or half encirclement hot tap fittings
- ◆ Size-on-size customized tap fittings
- ◆ Compatible with existing tapping equipment
- ◆ No special adapters required
- ◆ ANSI 150#, 300# & 600# series
- ◆ Sizes from 4" to 48" sizes

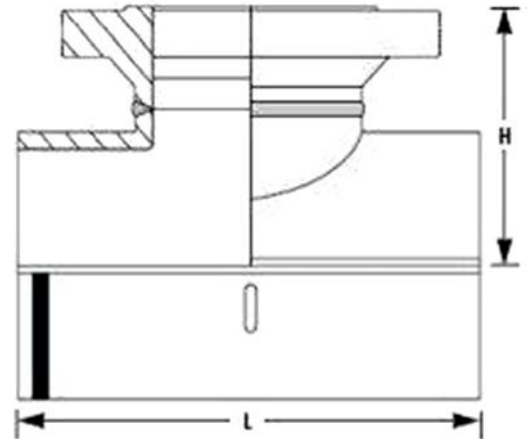

4" - 36" Split Line Stop Tee Fittings #150

Size (Inch)	Size (mm)	H (Inch)	H (mm)	L (Inch)	L (mm)
4	100	6.750	171	10.75	2733
6	150	8.375	206	14.00	356
8	200	9.687	246	14.00	356
10	250	11.250	286	20.00	508
12	300	12.375	314	22.00	559
14	350	13.500	343	26.00	660
16	400	15.000	381	30.00	762
18	450	16.500	419	33.00	838
20	500	17.687	449	36.00	914
22	550	18.875	479	40.00	1016
24	600	20.500	521	43.00	1092
26	650	21.125	537	47.00	1194
28	700	22.625	575	49.00	1245
30	750	26.250	667	51.00	1295
34	850	29.125	740	57.00	1448
36	900	30.500	775	60.00	1524

SPLIT LINE STOP TEE FITTINGS

4" - 36" Split Line Stop Tee Fittings #300

Size (Inch)	Size (mm)	H (Inch)	H (mm)	L (Inch)	L (mm)
4	100	7.125	181	10.75	273
6	150	8.375	213	14.00	356
8	200	10.062	255	14.00	356
10	250	11.250	286	20.00	508
12	300	13.000	330	20.00	559
14	350	15.125	384	26.00	660
16	400	17.250	438	30.00	762
18	450	18.500	470	33.00	838
20	500	19.750	502	36.00	914
22	550	20.875	530	40.00	1016
24	600	22.750	578	43.00	1092
26	650	24.875	632	47.00	1194
28	700	26.500	673	49.00	1245
30	750	28.000	667	51.00	1295
34	850	29.750	756	57.00	1448
36	900	31.000	762	60.00	1524

4" - 36" Split Line Stop Tee Fittings #600

Size (Inch)	Size (mm)	H (Inch)	H (mm)	L (Inch)	L (mm)
4	100	8.000	203	10.75	273
6	150	9.562	243	14.00	356
8	200	11.187	284	14.00	356
10	250	13.000	330	20.00	508
12	300	14.250	362	22.00	559
14	350	15.125	384	26.00	660
16	400	17.250	438	30.00	762
18	450	18.500	470	33.00	838
20	500	19.750	502	36.00	914
22	550	20.875	530	40.00	1016
24	600	22.750	578	43.00	1092
26	650	24.875	632	47.00	1194
28	700	26.500	673	49.00	1245
30	750	28.000	667	51.00	1295
34	850	29.750	756	57.00	1448
36	900	31.000	762	60.00	1524



Line Stop Fitting can be custom designed to your particular pipeline specifications. Blind flange kits and completion plugs are sold separately.

LOR PLUG

BSM mechanical products are easily integrated with BSM fittings.

We offer :

- ♦ Custom-fabrication to your specifications.
- ♦ Pre-engineered configurations.
- ♦ Eliminates the need for field welding.
- ♦ Factory-tested, factory-coated.
- ♦ Ideally suited for cast-iron piping applications.



We can fabricate a custom requirement. Our LOR Plug will be fitted with Split Line Stop Tee Fittings.

We have size from 4" - 36".

We manufacture in Indonesia with raw material applied to API/ASTM standards.

BLIND FLANGE

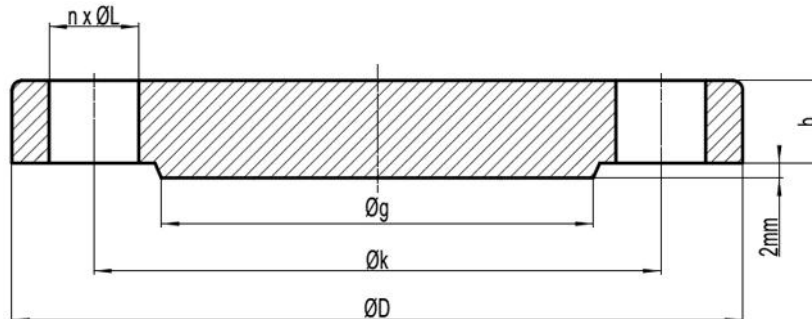

ANSI/ASME/ASA B16.5 300lb/sq.in. Flange BLIND-RF

ø	D	b	g	k	Holes	l	Kg.
1/2"	95,2	14,3	34,9	66,7	4	15,9	0,700
3/4"	117,5	15,9	42,9	82,5	4	19,0	1,200
1"	123,8	17,5	50,8	88,9	4	19,0	1,500
1 1/4"	133,3	19,0	63,5	98,4	4	19,0	2,000
1 1/2"	155,6	20,6	73,0	114,3	4	22,2	2,900
2"	165,1	22,2	92,1	127,0	8	19,0	3,400
2 1/2"	190,5	25,4	104,8	149,2	8	22,2	5,100
3"	209,5	28,6	127,0	168,3	8	22,2	7,000
3 1/2"	228,6	30,2	139,7	184,1	8	22,2	8,900
4"	254,0	31,7	157,2	200,0	8	22,2	11,800
5"	279,4	34,9	185,7	234,9	8	22,2	15,500
6"	317,5	36,5	215,9	269,9	12	22,2	21,300
8"	381,0	41,3	269,9	330,2	12	25,4	35,200
10"	444,5	47,6	323,8	387,3	16	28,6	57,000
12"	520,7	50,8	381,0	450,8	16	31,7	82,000
14"	584,2	54,0	412,7	514,3	20	31,7	106,000
16"	647,7	57,1	469,9	571,5	20	34,9	140,000
18"	711,2	60,3	533,4	628,6	24	34,9	178,000
20"	774,7	63,5	584,2	685,8	24	34,9	223,000
22"	838,2	66,7	641,2	742,9	24	41,3	270,000
24"	914,4	69,8	692,1	812,8	24	41,3	345,000

We also manufacture for ANSI class 300, 600 and 900.

WELD FITTINGS

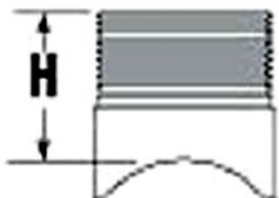

1 - 1/4" - 3" Weld Fittings #150

Size (Inch)	Size (mm)	H (Inch)	H (mm)
1 1/4	32	2.25	75
1 1/2	38	2.25	75
2	50	2.75	75
3	80	2.75	75

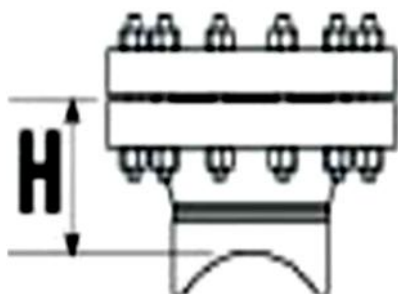

4" - 12" Weld Fittings #150

Size (Inch)	Size (mm)	H (Inch)	H (mm)
4	100	4.00	102
6	150	5.00	127
8	200	5.00	127
10	250	5.50	140
12	300	5.358	137



We are stockiest for other weld fittings like flange, elbow, reducer, tee, cap etc. with different size. ANSI 150.300 and 600.



EXPERIENCE

EXPERIENCE

Period	Work	Size	Qty	Company	End User
2011	Horizontal Hot Tapping Manual Driven	4"	1 Spot	PT. Radiant Utama KSO Masuma	
2011	Fabrication Hot Tap Line Stop Accessories	24"-32"		PT. Radiant Utama KSO Masuma	Chevron
2012	Supply Hot Tap & Line Stop Accessories	32"		PT. Radiant Utama	Pertamina Prabumulih
2012	Retrieval Lock O Ring Plug at Tanjung Jumlai	12"		PT. Bukaka Teknik Utama	Chevron
2012	Hot Tap Service Perusda Benuo Taka	2"	2 Spots	-	Perusda Benuo Taka
2013	Hot Tap Service Sepinggang Field Kalimantan	2"	2 Spots	PT. Bukaka Teknik Utama	Chevron
2013	Hot Tap Service Indorama Plant Summarecon	12"	2 Spots	PT. Utama Jaya Teknik	PT. Indorama
2013	Hot Tap Service Well Tango Kalimantan	2"	2 Spots	Pt. Bukaka Teknik Utama	Chevron
2014	Hot Tap Service Minas, Chevron SMO	4"	1 Spot	Masuma Muhale	Chevron
2014	Hot Tap Service Indorama Plant Summarecon	16"	1 Spot	PT. Utama Jaya Teknik	PT. Indorama
2014	Hot Tap Service Pertamina Dumai	18"	1 Spot	PT. Indrabas Purnama	PT. Pertamina

2014	Hot Tap Service Pertamina Dumai	8"	1 Spot	PT. Indrabas Purnama	PT. Pertamina
2015	Hot Tap Service Pertamina Dumai	2"	1 Spot	PERTAMINA RU II	PT. Pertamina
2015	Hot Tap Service & Stopples Line at Vertical Pipe Tunjungan Plaza IV & V	14"	4 Spots	Pakuwon Jati Tbk	Pakuwon Jati
2015	Hot Tap Service Tunjungan Plaza IV & V	12"	4 Spots	Pakuwon Jati Tbk	Pakuwon Jati
2015	Hot Tap Service Indorama Plant Summarecon	16"	1 Spot	PT. Utama Jaya Teknik	PT. Indorama
2015	Hot Tap & Stopples Line Service Santan Field Balikpapan	6"	4 Spots	PT. Bukaka Teknik Utama	Chevron
2016	Hot Tap & Stopples Line Service Pertamina Gedebage	12"	4 Spots	PT. Trinitas Usaha Tehnik	PT. Pertamina
2016	Hot Tap Service at Balikpapan Casing YO-12	2"	1 Spot	PT. Bukaka Teknik Utama	Chevron
2016	Hot Tap Service at Balikpapan Casing Foxtrot 2	2"	1 Spot	PT. Bukaka Teknik Utama	Chevron
2016	Hot Tap Service at Balikpapan Attaka UA	2"	4 Spot	PT. Bukaka Teknik Utama	Chevron
2016	Hot Tap Stopples Size 10" & 12" at Lawe-Lawe	10"& 12"	2 Spots	PT. Depriwangga	Chevron
2017	Hot Tap Service at CICO Balikpapan	4"	16 Spots	PT. Bukaka Teknik Utama	Chevron
2017	Hot Tap Service at West Seno Filed CICO	4"	1 Spot	PT. Depriwangga	Chevron

DOCUMENT

Certificate (CSMS, SKT Migas)

Dumai ,03 Maret 2015
No. 038 /E12400/2015-S0

Perihal : **Surat Keterangan Prakuualifikasi CSMS**

Kepada
PT. Brilian Sukses Mandiri
Alamat : Jln. Baung No. 34 Jagakarsa Lenteng Agung
Telp : -
Fax : -
Email : -
Jakarta

Setelah dilakukan assessment Pra Kualifikasi Contractors Safety Management System yang dilaksanakan pada tanggal 04 Februari 2015 oleh Tim Assessment CSMS Pertamina Refinery Unit II kepada **PT. Brilian Sukses Mandiri**, dengan ini disampaikan penilaian hasil assessment sebagai berikut :

Sub Total	Item	Nilai
1	Komitmen Manajemen	26
2	Pembinaan	12
3	Prosedur	14
4	Peralatan	12
5	Tambahan	00
Total Score		64

Risk Category : **High Risk**

Surat Keterangan CSMS ini berlaku sampai tanggal **03 Maret 2017**

PT Pertamina (Persero) RU II
Procurement Manager

k

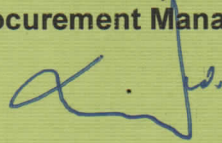

GR

WIDODO TRI RAHARDJO

- *) 1. Apabila Surat Keterangan CSMS telah habis masa berlakunya maka Pertamina akan melakukan kembali verifikasi dokumen dan assessment Pra Kualifikasi CSMS.
- 2. Apabila dikemudian hari ditemukan ketidaksesuaian, maka Tim CSMS dapat mencabut Surat Keterangan lulus CSMS kontraktor ini.

KEMENTERIAN ENERGI DAN SUMBER DAYA MINERAL REPUBLIK INDONESIA
DIREKTORAT JENDERAL MINYAK DAN GAS BUMI

Gedung Migas, Jalan H.R. Rasuna Said Kav. B-5, Jakarta 12910

Telex :

Kawat : Ditjen Migas

Tromol Pos : 1296/Jkt.100.12

Telepon : 5268910 (hunting)

Nomor : 6210 /19.11/DMT/2016
Lampiran : 1 (satu lembar)
Hal : Surat Keterangan Terdaftar Migas

17 Oktober 2016

Yang terhormat,
Direktur **PT Brilian Sukses Mandiri**
Jl. Baung No. 3A Jagakarsa – Lenteng Agung
Jakarta Selatan 12610

Menunjuk surat Saudara Nomor : BSM-101/X/2016 tanggal 10 Oktober 2016 perihal Permohonan Pendaftaran Perusahaan Penunjang Minyak dan Gas Bumi dan berdasarkan hasil evaluasi terhdap kelengkapan dokumen, kami sampaikan bahwa **PT Brilian Sukses Mandiri** dapat didaftarkan sebagai perusahaan jasa penunjang Migas bidang usaha **JASA KONSTRUKSI** subbidang **JASA PELAKSANAAN dan PENGAWASAN KONSTRUKSI** dengan bagian subbidang:

MEKANIKAL	Konstruksi Perpipaan minyak, gas, geothermal (Pekerjaan Rekayasa)
Layanan Jasa Enjiniring Terpadu	Jasa Enjiniring Terpadu

Sehubungan dengan ini kami kirimkan surat keterangan terdaftar Migas sebagaimana terlampir, dengan nomor:

1277 /SKT-01/DMT/2016

dan satu berkas dokumen perusahaan. Apabila diperlukan, sewaktu-waktu kami dapat mengevaluasi kembali dokumen tersebut untuk pembinaan dan pengawasan.

Atas perhatian Saudara, kami ucapkan terima kasih.



Direktur Teknik dan Lingkungan Migas

Dr. Ir. Diko Siswanto, MBA.

NIP. 19650523 199203 1016

Tembusan:
Sekretaris Ditjen Migas

KEMENTERIAN ENERGI DAN SUMBER DAYA MINERAL REPUBLIK INDONESIA
DIREKTORAT JENDERAL MINYAK DAN GAS BUMI
SURAT KETERANGAN TERDAFTAR

No. 1277 /SKT-01/DMT/2016

Memperhatikan surat permohonan pendaftaran perusahaan usaha penunjang Minyak dan Gas Bumi Nomor: 005/KMG/SK/VII/2016 tanggal 25 Juli 2016 dan berdasarkan;

1. Undang-Undang Republik Indonesia Nomor 22 Tahun 2001;
2. Peraturan Pemerintah Republik Indonesia Nomor 17 Tahun 1974;
3. Peraturan Pemerintah Republik Indonesia Nomor 11 Tahun 1979;
4. Peraturan Pemerintah Republik Indonesia Nomor 35 Tahun 2004;
5. Peraturan Pemerintah Republik Indonesia Nomor 36 Tahun 2004;
6. Peraturan Menteri Energi dan Sumber Daya Mineral Nomor 27 Tahun 2008; dan
7. Keputusan Direktur Jenderal Minyak dan Gas Bumi Nomor 15784.K/10DJM.S/2010.

DIREKTUR JENDERAL MINYAK DAN GAS BUMI

dengan ini memberikan Surat Keterangan Terdaftar kepada:

Nama Perusahaan : **PT Brilian Sukses Mandiri**
Alamat : Jl. Baung No. 3A, Jagakarsa – Lenteng Agung
Jakarta Selatan 12610

sebagai perusahaan jasa penunjang Migas bidang usaha **JASA KONSTRUKSI** subbidang **JASA PELAKSANAAN dan PENGAWASAN KONSTRUKSI** dengan bagian subbidang:

MEKANIKAL	Konstruksi Perpipaan minyak, gas, geothermal (Pekerjaan Rekayasa)
Layanan Jasa Enjiniring Terpadu	Jasa Enjiniring Terpadu

Surat Keterangan Terdaftar ini diberikan dengan ketentuan sebagai berikut:

1. Perusahaan wajib mengikuti ketentuan peraturan perundang-undangan yang berlaku dalam melaksanakan kegiatan usahanya.
2. Perusahaan wajib mengutamakan penggunaan barang dan jasa produksi dalam negeri.
3. Perusahaan wajib mengutamakan penggunaan tenaga kerja Indonesia dan wajib melaksanakan program pengembangan tenaga kerja Indonesia.
4. Perusahaan wajib menyampaikan laporan kegiatan usaha secara berkala setiap 6 (enam) bulan sekali kepada Direktur Teknik dan Lingkungan Migas.
5. Perusahaan dapat dikenakan sanksi berupa pencabutan Surat Keterangan Terdaftar ini apabila, tidak mematuhi ketentuan peraturan perundang-undangan yang berlaku, dan/atau tidak melakukan kegiatan usaha selama 3 (tiga) tahun berturut-turut, dan/atau tidak mematuhi kewajiban-kewajiban yang ditetapkan dalam Surat Keterangan Terdaftar ini.
6. Surat Keterangan Terdaftar ini berlaku selama 3 (tiga) tahun + 3 (tiga) tahun perpanjangan otomatis sampai dengan tanggal 17 Oktober 2022.

Dikeluarkan di Jakarta
Pada tanggal 17 Oktober 2016

a.n. **Direktur Jenderal Minyak dan Gas Bumi**
Direktur Teknik dan Lingkungan Migas



Dr. Ir. Dioko Siswanto, MBA

**KEMENTERIAN ENERGI DAN SUMBER DAYA MINERAL REPUBLIK INDONESIA
DIREKTORAT JENDERAL MINYAK DAN GAS BUMI**

Gedung Migas, Jalan H.R. Rasuna Said Kav. B-5, Jakarta 12910

Telex :

Kawat : Ditjen Migas

Tromol Pos : 1296/Jkt.100.12

Telepon : 5268910 (hunting)

Nomor : 6209 /19.11/DMT/2016
Lampiran : 1 (satu lembar)
Hal : Surat Keterangan Terdaftar Migas

17 Oktober 2016

Yang terhormat,
Direktur **PT Brilian Sukses Mandiri**
Jl. Baung No. 3A Jagakarsa – Lenteng Agung
Jakarta Selatan 12610

Menunjuk surat Saudara Nomor : BSM-101/X/2016 tanggal 10 Oktober 2016 perihal Permohonan Pendaftaran Perusahaan Penunjang Minyak dan Gas Bumi dan berdasarkan hasil evaluasi terhdap kelengkapan dokumen, kami sampaikan bahwa **PT Brilian Sukses Mandiri** dapat didaftarkan sebagai perusahaan jasa penunjang Migas bidang usaha **JASA NONKONSTRUKSI** subbidang **JASA LAINNYA** dengan bagian subbidang:

JASA PENYEDIA MATERIAL	Material Logam Setengah Jadi , antara lain: Pipa, <i>Casing</i> , <i>Flange</i> , <i>Fitting</i> , <i>Elbow</i> , <i>Tee</i> , <i>Steel Bar</i> .
-------------------------------	--

Sehubungan dengan ini kami kirimkan surat keterangan terdaftar Migas sebagaimana terlampir, dengan nomor:

1276 /SKT-02/DMT/2016

dan satu berkas dokumen perusahaan. Apabila diperlukan, sewaktu-waktu kami dapat mengevaluasi kembali dokumen tersebut untuk pembinaan dan pengawasan.

Atas perhatian Saudara, kami ucapkan terima kasih.



Direktur Teknik dan Lingkungan Migas

Dr. Ir. Djoko Siswanto, MBA.
NIP. 19650523 199203 1016

Tembusan:
Sekretaris Ditjen Migas

KEMENTERIAN ENERGI DAN SUMBER DAYA MINERAL REPUBLIK INDONESIA
DIREKTORAT JENDERAL MINYAK DAN GAS BUMI
SURAT KETERANGAN TERDAFTAR

No. 1276 /SKT-02/DMT/2016

Memperhatikan surat permohonan pendaftaran perusahaan usaha penunjang Minyak dan Gas Bumi Nomor: 005/KMG/SK/VII/2016 tanggal 25 Juli 2016 dan berdasarkan;

1. Undang-Undang Republik Indonesia Nomor 22 Tahun 2001;
2. Peraturan Pemerintah Republik Indonesia Nomor 17 Tahun 1974;
3. Peraturan Pemerintah Republik Indonesia Nomor 11 Tahun 1979;
4. Peraturan Pemerintah Republik Indonesia Nomor 35 Tahun 2004;
5. Peraturan Pemerintah Republik Indonesia Nomor 36 Tahun 2004;
6. Peraturan Menteri Energi dan Sumber Daya Mineral Nomor 27 Tahun 2008; dan
7. Keputusan Direktur Jenderal Minyak dan Gas Bumi Nomor 15784.K/10DJM.S/2010.

DIREKTUR JENDERAL MINYAK DAN GAS BUMI

dengan ini memberikan Surat Keterangan Terdaftar kepada:

Nama Perusahaan : **PT Brilian Sukses Mandiri**
Alamat : Jl. Baung No. 3A, Jagakarsa – Lenteng Agung
Jakarta Selatan 12610

sebagai perusahaan jasa penunjang Migas bidang usaha **JASA NONKONSTRUKSI** subbidang **JASA LAINNYA** dengan bagian subbidang:

JASA PENYEDIA MATERIAL	Material Logam Setengah Jadi , antara lain: <i>Pipa, Casing, Flange, Fitting, Elbow, Tee, Steel Bar.</i>
-------------------------------	---

Surat Keterangan Terdaftar ini diberikan dengan ketentuan sebagai berikut:

1. Perusahaan wajib mengikuti ketentuan peraturan perundang-undangan yang berlaku dalam melaksanakan kegiatan usahanya.
2. Perusahaan wajib mengutamakan penggunaan barang dan jasa produksi dalam negeri.
3. Perusahaan wajib mengutamakan penggunaan tenaga kerja Indonesia dan wajib melaksanakan program pengembangan tenaga kerja Indonesia.
4. Perusahaan wajib menyampaikan laporan kegiatan usaha secara berkala setiap 6 (enam) bulan sekali kepada Direktur Teknik dan Lingkungan Migas.
5. Perusahaan dapat dikenakan sanksi berupa pencabutan Surat Keterangan Terdaftar ini apabila, tidak mematuhi ketentuan peraturan perundang-undangan yang berlaku, dan/atau tidak melakukan kegiatan usaha selama 3 (tiga) tahun berturut-turut, dan/atau tidak mematuhi kewajiban-kewajiban yang ditetapkan dalam Surat Keterangan Terdaftar ini.
6. Surat Keterangan Terdaftar ini berlaku selama 3 (tiga) tahun + 3 (tiga) tahun perpanjangan otomatis sampai dengan tanggal 17 Oktober 2022.

Dikeluarkan di Jakarta
Pada tanggal 17 Oktober 2016

a.n. **Direktur Jenderal Minyak dan Gas Bumi**
Direktur Teknik dan Lingkungan Migas



Dr. Ir. Djoko Siswanto, MBA
NIP. 19650523 199203 1016